

ANY OTHER STREETS
LINING THE PROPERTY
SHALL BE SHOWN

ITEMS TO SHOW ON THE SITE PLAN;

- WIDTH OF THE PROPERTY A _____
- DEPTH OF THE PROPERTY B _____
- ALL EXISTING STRUCTURES.
- ANY SWALES, WATERCOURSES OR EASEMENTS.
- PROPOSED STRUCTURE(S) WITH DIMENSIONS
(FENCE, DECK, BALCONY, SUNROOM, HOUSE
ADDITION, POOL, GAZEBO, SHED, GARAGE).
- DIMENSIONS BETWEEN THE PROPOSED STRUCTURE
AND THE SURROUNDING PROPERTY LINES.
- IF A DETACHED STRUCTURE IS PROPOSED, THE
DIMENSION BETWEEN THE STRUCTURE AND THE
MAIN DWELLING SHALL BE SHOWN.

REFER TO REAR SIDE OF PAGE FOR EXAMPLES

TITLE: TYPICAL SITE PLAN FOR PROPOSED STRUCTURES

ADDRESS:

APPLICANT SIGNATURE:

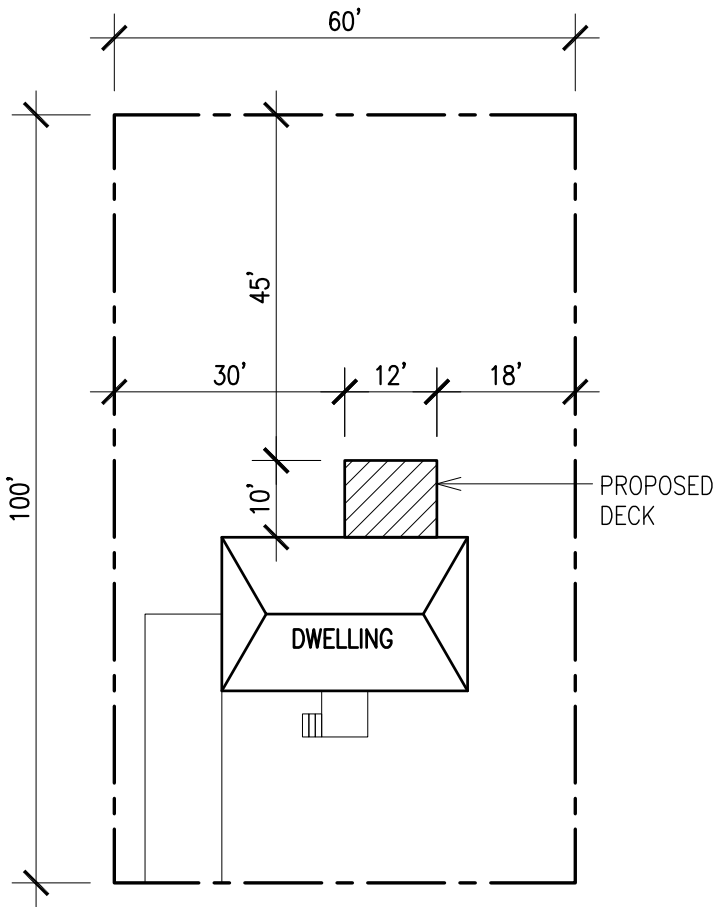

SITE PLAN EXAMPLE – PROPOSED DECK

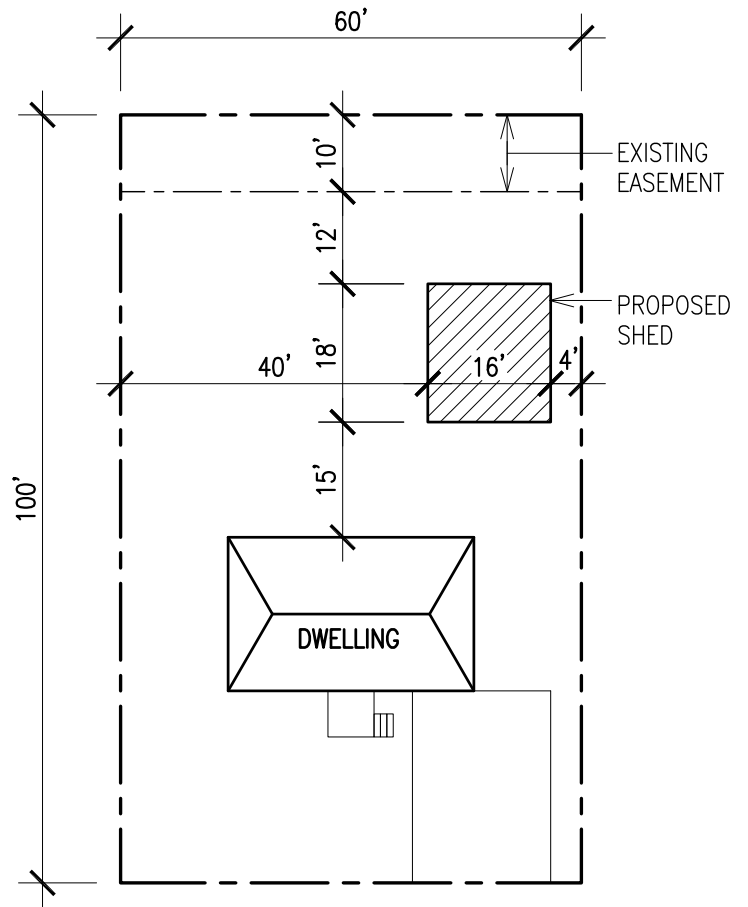

SITE PLAN EXAMPLE – PROPOSED SHED

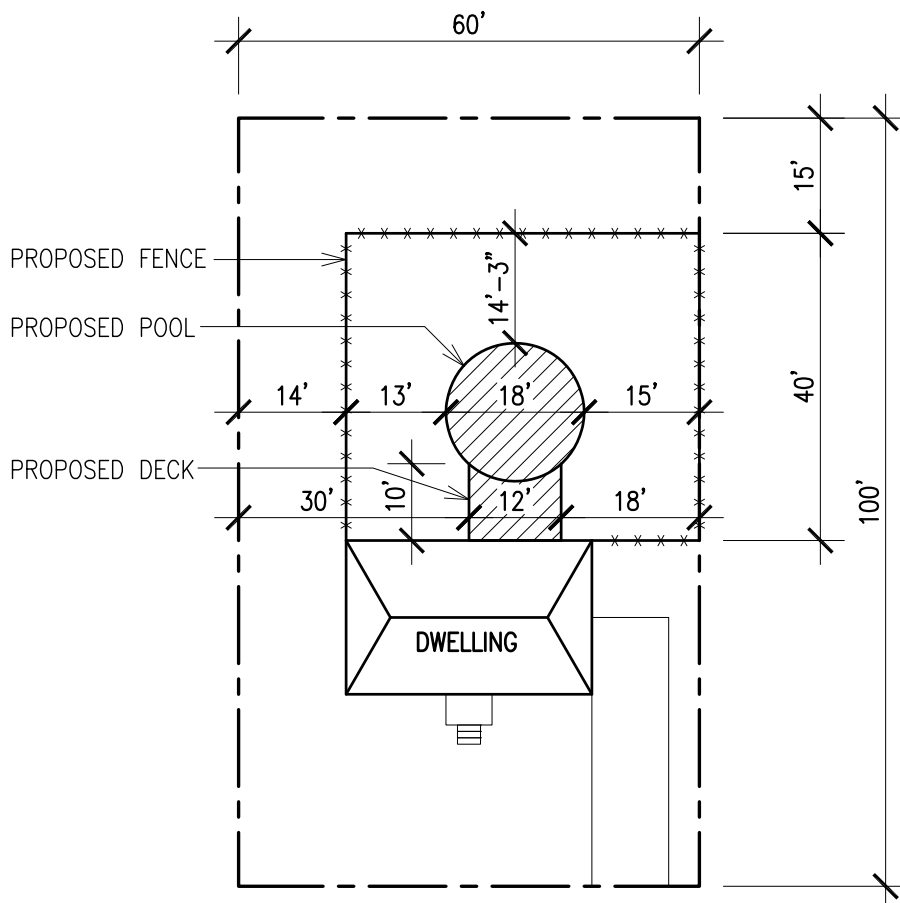

SITE PLAN EXAMPLE – PROPOSED POOL, DECK & FENCE